

**Features**

- : 940nm wavelength range
- : 10mW VCSEL
- : Gaussian beam profile
- : High reliability
- : Other configurations available on request

**Description**

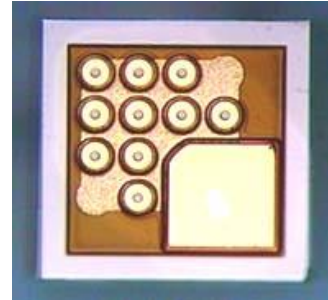

**Applications**

- : Consumer electronics
- : Safety sensor

**Absolute Maximum Ratings**

Parameter	Rating
Storage Temperature	-40 to 85 °C
Operating Temperature	-10 to 70 °C
Continuous Forward Current	30mA
Continuous Reverse Voltage	5V (@10µA)

**Dimensions**

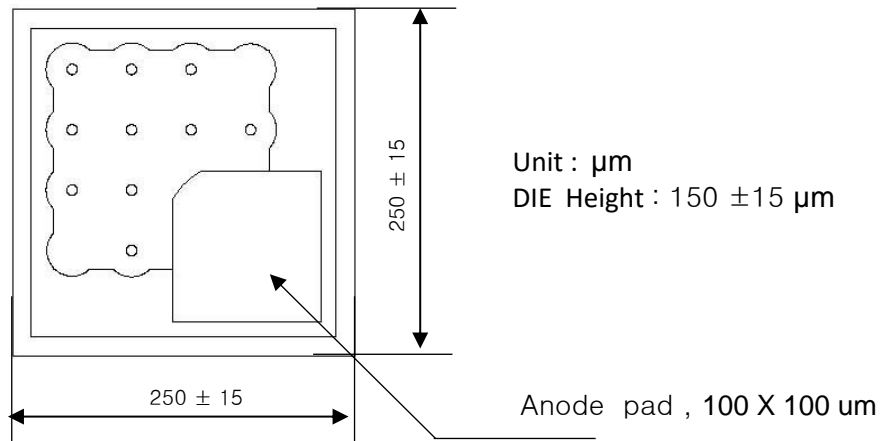

Electro-Optics Characteristics (  $T_a=25^\circ\text{C}$  unless otherwise stated)

Parameters	Symbol	Specified			Unit	Test Conditions
		Min.	Typ.	Max.		
Threshold Current	$I_{th}$		6.0		mA	CW
$I_{th}$ Temperature Variation	$\Delta I_{th}$		3.0		mA	$T_a = -10$ to $70^\circ\text{C}$
Slope Efficiency	$\eta$	0.4	0.5		W/A	$I_f = 20$ mA
$\eta$ Temperature Variation	$\Delta\eta / \Delta T$		-0.5		% / $^\circ\text{C}$	$T_a = -10$ to $70^\circ\text{C}$ at 20mA
Optical Output Power	$P_o$		12		mW	$I_f = 20$ mA
Peak Wavelength	$\lambda_p$	930	940	950	nm	$I_f = 20$ mA
$\lambda$ Temperature Variation	$\Delta\lambda / \Delta T$		0.06		nm / $^\circ\text{C}$	$T_a = -10$ to $70^\circ\text{C}$ at 20mA
Beam Divergence	$\Theta$		10		$^\circ$	$P_o = 10$ mW (FWHM)
Operating Voltage	$V_f$		2.1	2.4	V	$I_f = 20$ mA
Breakdown Voltage	$V_b$		-10		V	
Dynamic Resistance	$R_d$		20	40	Ohm	$I_f = 20$ mA

Notes

\* These specifications are subject to change without notice.

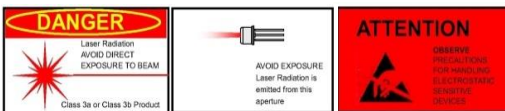

<b>NOTICE</b>	The inherent design of this component causes it to be sensitive to electrostatic discharge(ESD). To prevent ESD-induced damage and/or degradation to equipment, take normal ESD precautions when handling this product
<b>DANGER</b>	The VCSEL is a class IIIb laser and should be treated as a potential eye hazard. Due to the size of the component, the applicable warning logotype, aperture label, and certification / identification label cannot be placed on the component itself.