

940nm 8mW VCSEL Chip VC-0940P-006M-26-2A0

Features

- 940nm single wavelength
- Low wavelength drift
- Oxide isolation technology
- Low threshold current
- Small emission area
- Easy to collimate

Applications

- Sensing i.e. Proximity
- Consumer electronics
- Active optical cables
- Medical applications
- Range finder sensors
- Modulation and width >1GHz

Part Number	Description
VC-0940P-008M-26-2A0	940nm 8mW VCSEL Chip

PRODUCT IDENTIFY

CODE RULE

VC - 0940 P- 008 M- 26- 2 A 0

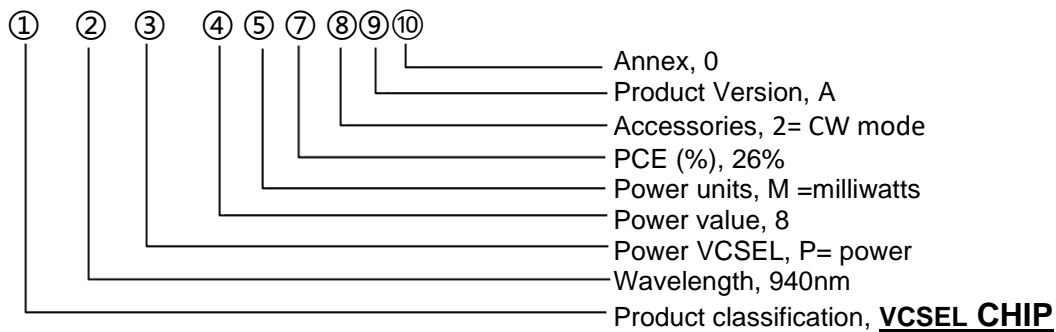

I. Absolute maximum ratings

Parameter	Symbol	Rating	Unit
Operating Temp	Top	-40 to 60	°C
Storage Temp	Tsto	-40 to 85	°C
Reflow Soldering Temperature	Tsdr	320°C(10s)	°C
Reverse Voltage	Vr	5	V
Maximum Continuous Current	Imax	20	mA
ESD exposure (Human body) model	ESD	2K	V

Note:

1. Stresses greater than those listed under “Absolute Maximum Ratings” may cause permanent damage to the device. This is a stress rating only and functional operation of the device at these or other conditions above those indicated in the operations section for extended periods of time may

affect reliability.

- In its maximum rating diode laser operation could damage its performance or cause potential safety hazard such as equipment failure.
- Electrostatic discharge is the main reason for the laser fault of the diode. Take effective precautions against ESD. When dealing with laser diodes, use the wrist strap, grounding work surface and strict antistatic technology.

II. Optical-electrical characteristics @25°C CW mode

Parameters	Symbol	Test Conditions	Min.	Typ.	Max.	Units
Optical Power Output	P_o	$I_F = 13\text{mA}$		8	10	mW
Threshold Current	I_{TH}	-	-	1.2	-	mA
Slope Efficiency	η	$P_o = 8\text{mW}$	-	0.55	-	mW/mA
Power Conversion Efficiency	PCE	$I_F = 13\text{mA}$	-	26.5	27.4	%
Peak Wavelength	λ_P	$I_F = 13\text{mA}$	930	940	950	nm
Laser Forward Voltage	V_F	$I_F = 13\text{mA}$	-	2.5	-	V
Series Resistance	R_S	$I_F = 13\text{mA}$	-	48		Ohm
Wavelength shift	$\partial\lambda_P/\partial T$	$I_F = 13\text{mA}$	-	-	0.07	nm/°C

Note: Electro-Optical Characteristic with a package or diffuser would require further evaluation. Values are based on limited sample size and estimated values.

III. Environmental Specifications

Parameter	Symbol	Min.	Typ.	Max.	Units	Ref.
Case Operating Temp	T_{op}	-40	25	75	°C	-
Storage Temp	T_{sto}	-40	25	85	°C	-

IV. LIV Graph (25°C)

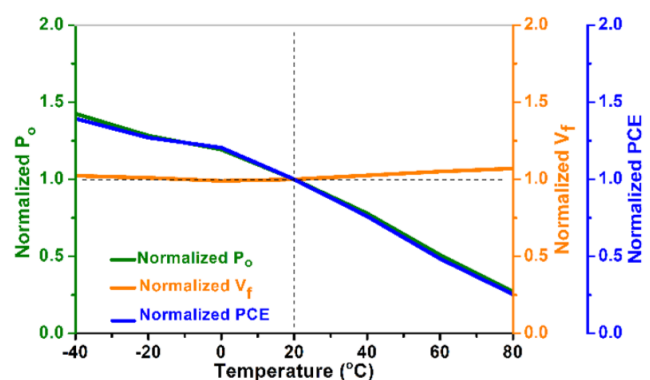
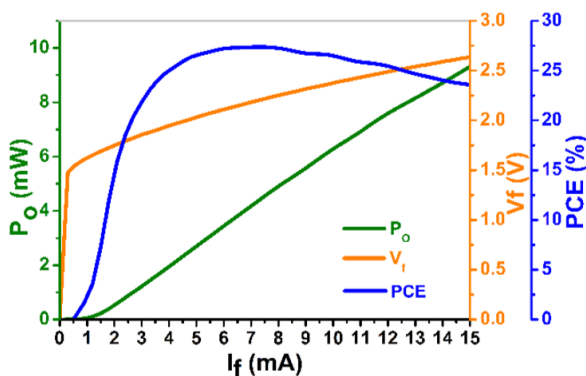

Note: 1. LIV graph was measured at 25 °C (left); power output, voltage and power conversion efficiency variation trend with changed operating temperature (right, normalized).

- Forward Voltage (V_F) measurement allowance is ± 0.1 V.
- Peak Wavelength (λ_P) measurement allowance is ± 1.5 nm.
- Others measurement allowance is $\pm 10\%$.

V. Mechanical Schematics (unit:mm)

Device: 1 aperature

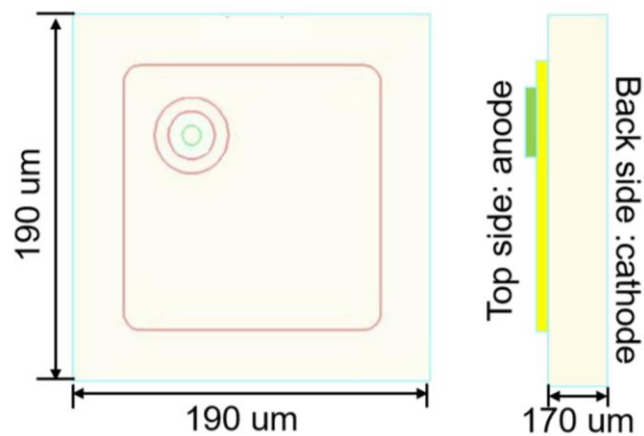

Note: There may be some changes between sample and drawing, thus, the actual spec please refer to the sample that you received. And if any question please contact us.

VI. Packaging Suggestion

For packaging, the user should use high thermal conductive substrate with AlN or copper; the user also attaches die onto the substrate using high thermal conductive materials such as nanosilver gel or AuSn.

The user should have the equipments such as die attachment, wire bonder etc., which should be located in 1000 class clean room. For further assistance in need, please feel free to contact Brightintelligence! We would work with you to solve your issues.

VII. Treatment and protection measures

Soldering precautions

The operator should examine grounding of machines before die attachment; and operator should wear electrostatic bracelet to prevent die from damaging caused by electrostatic discharging.

Storage precautions

VCSEL bare dies must be stored in Nitrogen gas cabinet with >99% concentration at 20°C.

VIII. Revision history

Revision	Date	Description
V.01	2020/02/26	The first official edition (11C1)
V.02	2020/04/08	Update part name

**Brightlaser reserves the right to make modification at any time due to improved design from time to time, the merit behind is in order to supply the best product possible.