

850nm 8mW VCSEL Diode

VD-0850C-008M-XX-0A0

FEATURES

- 850nm single wavelength
- Low wavelength drift
- Oxide isolation technology
- Low threshold current
- Small emission area
- Easy to collimate

APPLICATIONS

- Proximity Sensor
- Consumer electronics
- Active optical cables
- Medical applications
- Range finder sensors
- Modulation and width >2GHz

| Part Number | Description |
|----------------------|-----------------------|
| VD-0850C-008M-XX-0A0 | 850nm 8mW VCSEL Diode |

PRODUCT IDENTIFY

Code Rules

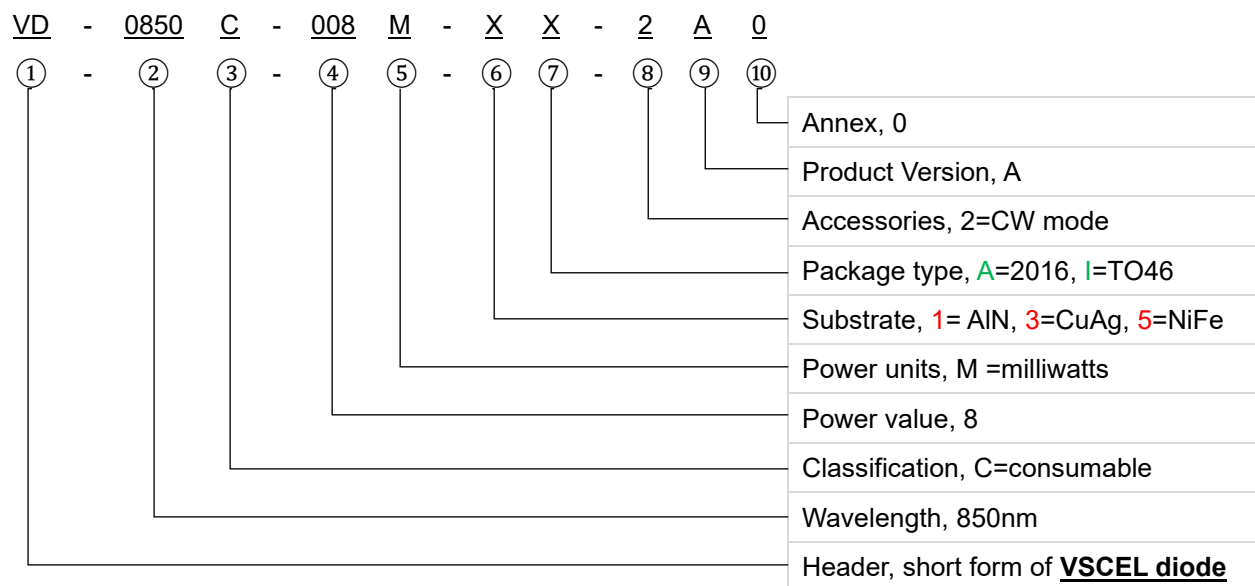

I. Absolute maximum ratings

| Parameter | Symbol | Rating | Unit |
|---------------------------------|-----------|-------------|------|
| Case Operating Temperature | T_{op} | -40 to +70 | °C |
| Storage Temperature | T_{sto} | -40 to +85 | °C |
| Reflow Soldering Temperature | T_{sdr} | 260°C (10s) | \ |
| Reverse Voltage | V_r | 5 | V |
| Maximum Continuous Current | I_{max} | 20 | mA |
| ESD exposure (Human body) model | ESD | 2K | V |

Note:

1. Stresses greater than those listed under “Absolute Maximum Ratings” may cause permanent damage to the device. This is a stress rating only and functional operation of the device at these or other conditions above those indicated in the operations section for extended periods of time may affect reliability.
2. In its maximum rating diode laser operation could damage its performance or cause potential safety hazard such as equipment failure.
3. Electrostatic discharge is the main reason for the laser fault of the diode. Take effective precautions against ESD. When dealing with laser diodes, use the wrist strap, grounding work surface and strict antistatic technology.

II. Optical-electrical characteristics @25°C , CW mode

| Parameters | Symbol | Condition | Min. | Typ. | Max. | Unit |
|-----------------------------|--------------------------|--------------|------|------|------|----------|
| Threshold Current | I_{th} | | - | 0.5 | - | mA |
| Forward Current | I_F | | - | 11.2 | - | mA |
| Optical Power | P_o | $I_F=11.2mA$ | - | 8 | 10 | mW |
| Laser Forward Voltage | V_f | $I_F=11.2mA$ | - | 2.5 | 2.7 | V |
| Power conversion efficiency | η | $I_F=11.2mA$ | - | 27.5 | - | % |
| Slope efficiency | SE | $P_o=8mW$ | - | 0.6 | - | W/A |
| Series Resistance | R | $I_F=11.2mA$ | - | 60 | - | Ω |
| Peak Wavelength | - | $I_F=11.2mA$ | 840 | 850 | 860 | nm |
| Spectral width | FWHM _S | | - | 2 | - | nm |
| Wavelength-Temp. Drift | $\Delta\lambda/\Delta T$ | $I_F=11.2mA$ | - | 0.07 | - | nm/°C |
| Beam divergence | FWHM _B | | - | 19 | - | deg |
| No. of Emission Aperture | | | - | 1 | - | |

Note: Electro-Optical Characteristic with a package or diffuser would require further evaluation. Values are based on limited sample size and estimated values.

III. Typical Performance

a. LIV curve

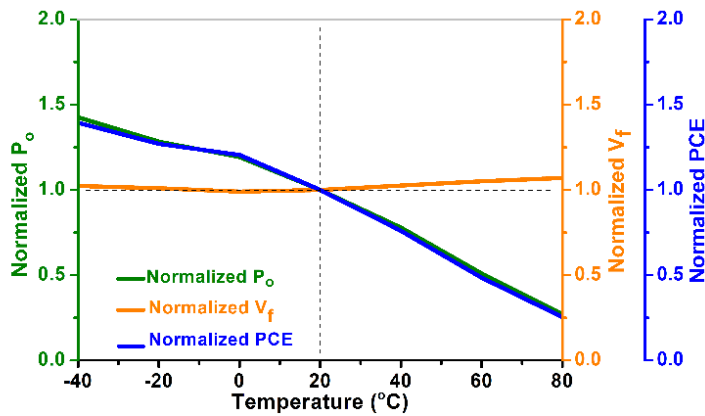
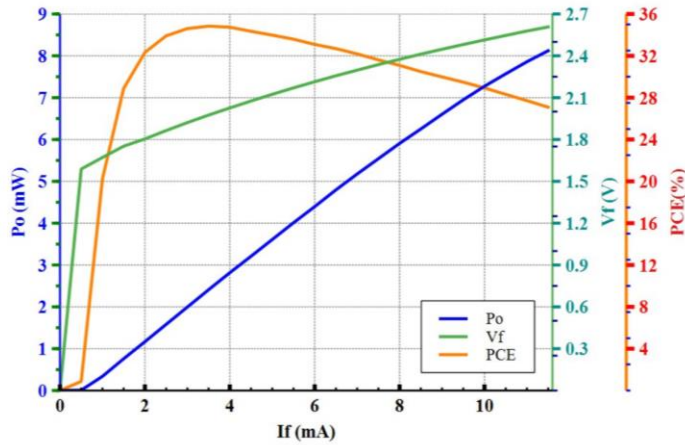

Note:

1. LIV graph was measured at 25 °C (left); power output, voltage and power conversion efficiency variation trend with changed operating temperature (right, normalized).
2. Forward Voltage (VF) measurement allowance is ± 0.1 V.
3. Peak Wavelength (λ P) measurement allowance is ± 1.5 nm.
4. Others measurement allowance is $\pm 10\%$.

b. Typical Spectral Width

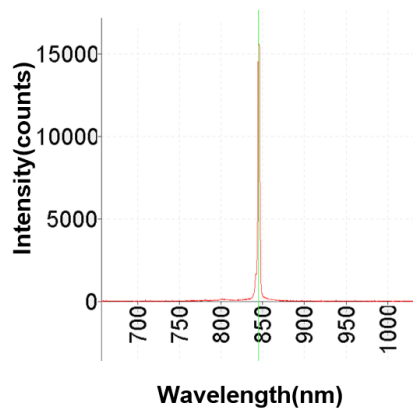

IV. Mechanical Schematics

VD-0850C-008M-3A-0A0 with Substrate 3=CuAg and Package A=2016 (unit: mm)

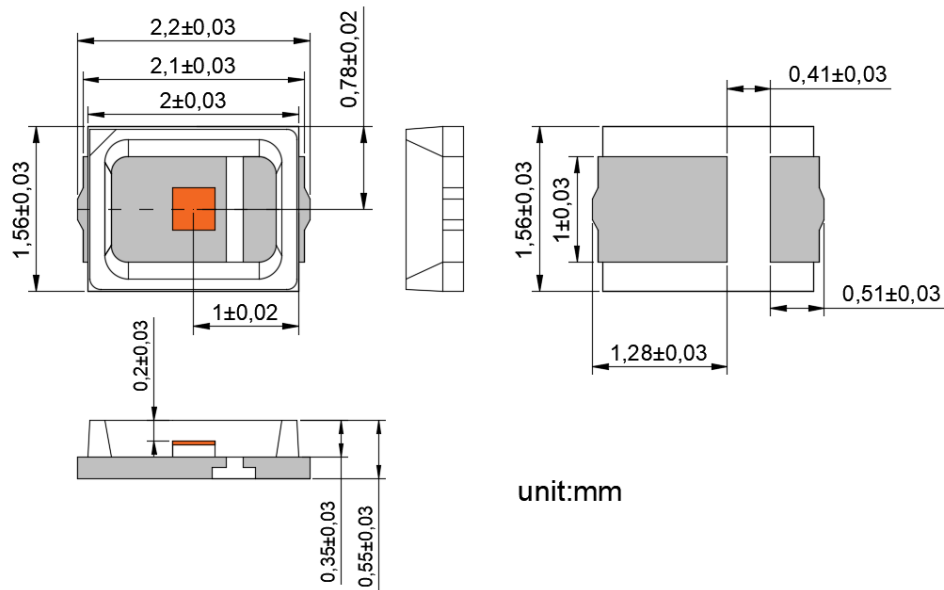

VD-0850C-008M-1A-0A0 with Substrate 1=AlN and Package A=2016 (unit: mm)

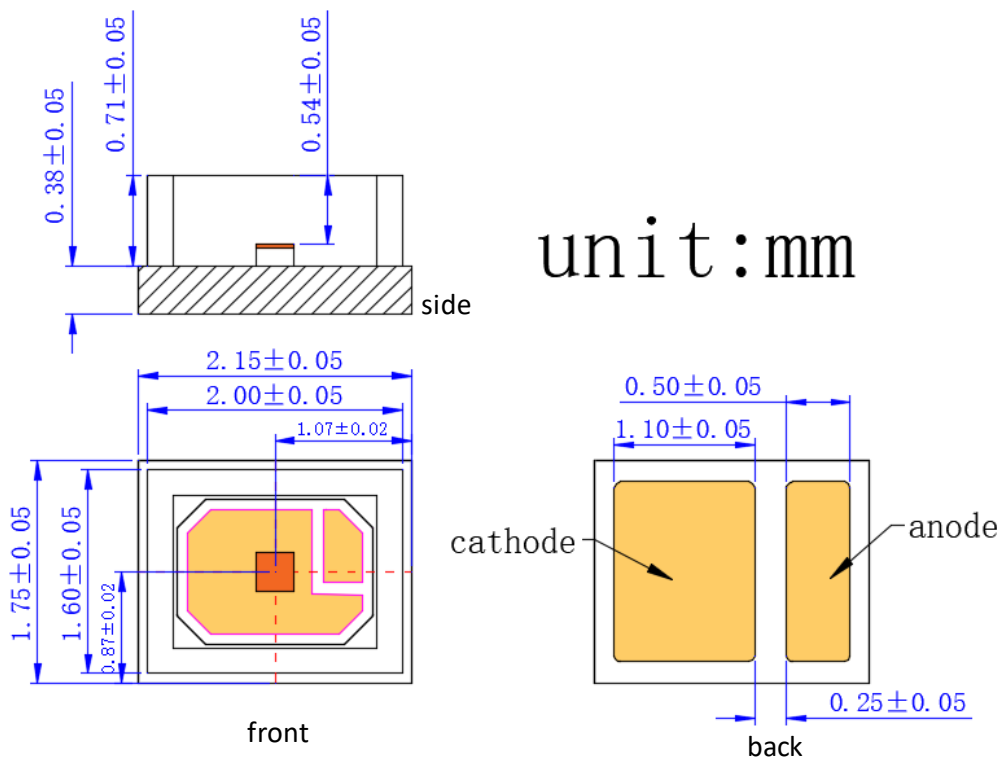

VD-0850C-008M-5I-0A0 with Substrate 5=NiFe and Package I=To46 (unit: mm)

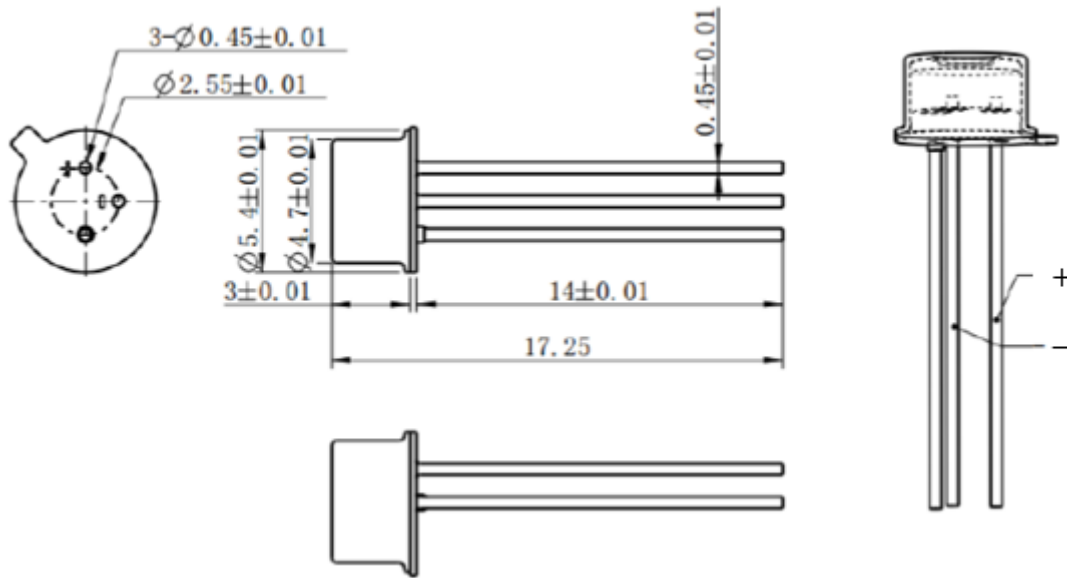

Note: There may be some changes between sample and drawing · thus · the actual spec please refer to the sample that you received. And if any inquires please contact us.

V. SMT Reflow Soldering Curve

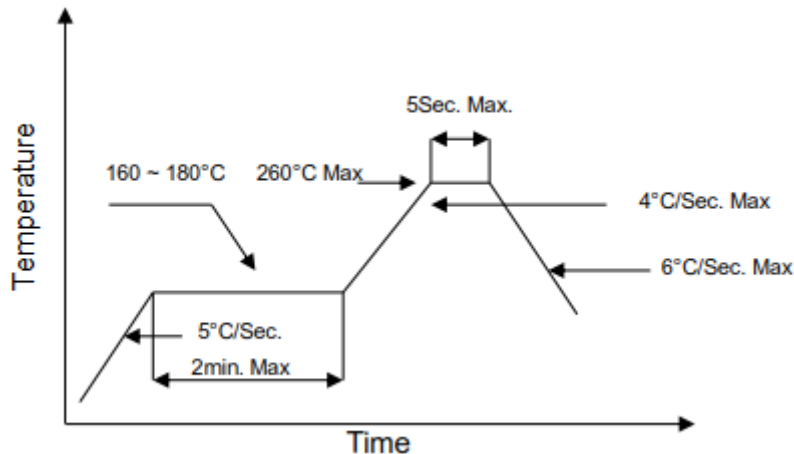

Note: Reflow soldering can be operated only one time. During the temperature ramp-up, no forces may be exerted on the diode which could deform or damage them. After soldering completed, please also do not process until the product temperature ramp down to room temperature.

VI. Treatment and protection measures

Soldering precautions

The temperature of soldering iron must be controlled under 300°C during manual soldering. Also, VCSEL can be only soldered one time with the soldering time less than 3s. but, it is very hard to control the soldering temperature and homogenize solder paste

because of the smaller size of VCSEL. In addition, it is easy to damage VCSEL structure even causes VCSEL losing efficacy. So, we advise you to use re-flow soldering machine for operation.

Storage precautions

Our products were sealed by aluminum foil bag attaching packed desiccant, they are moisture proof and anti-static. Please handle these gently to avoid damage. At the same time, please be ready for storage and take some moisture-proof measures to keep the diode away from dampness that may causes reliability failure.

Before opening, the diode must be saved for at least 90 days below 30 °C with 60% RH. After opening, the diode must be kept in an environment that temperature lower than 30 °C and humidity lower than 60% RH and used up within 24 hours. When the storage humidity reaches and exceeds 60%, the products must be dehumidified at 60 °C for more than 24 hours before use.

Others

1. Please use solder paste to cure the laser diode.
2. Please make sure that the heat of the diode has been completely conducted to metal shell, to avoid affecting the optical power output.
3. This diode can be only used in constant voltage and current.
4. Operating voltage and current, refer to the table in paragraph II.
5. Please do not aim the laser to people or animal.
6. You can observe the laser spot through an image monitoring equipment.
7. Please do not touch the diode surface by naked hands or squeeze the sealant on the diode surface, or it may cause wrong optical angle and distorted laser spot, even damage the diode.
8. Please use ceramic suction nozzle to absorb the diode, to avoid the diode sticking to the nozzle.
9. Please add a 0.02 s blowing action after locating the laser diode to aluminum substrate.

VII. Revision History

| Revision | Date | Description |
|-----------------|-------------|--|
| V.01 | 2020/03/12 | The first official edition [003C5,003C6] |
| V.02 | 2020/03/26 | Update part name |

Note: Brightlaser reserves the right to make modification at any time due to improved design from time to time, the merit behind is to supply the best product possible.